

MODERN

Cronulla Home

An unpretentious residence successfully integrates statuesque design pieces to make striking interior statements.

Designer: Amber Road Design

Photographer: Prue Ruscoe



‘THE DESIGN AIMS TO ENCOURAGE ENGAGEMENT AND COMMUNICATION WITHIN THE FAMILY, SHOWCASING DISTINCT FEATURES TO AID THIS.’



PROJECT



‘THE FURNITURE SELECTION IS A REFLECTION OF THE HOMEOWNERS’ MINIMALIST TENDENCIES.’

When a Sydney family briefed Amber Road interior and landscape architects for their new home, their main objective was to "keep it as unpretentious and simple as possible" for their family of four. The resulting design references a distinctive Japanese aesthetic - Wabi Sabi, which focuses on simple, slow and uncluttered spaces that celebrate the human effect, rather than machine-made or mass-production. The design aims to encourage engagement and communication within the family, showcasing distinct

features to aid this. Responsible for the project from the ground up; from the design and building work through to sourcing furniture, customising joinery and selecting artwork - Amber Road cleverly created a home that exudes a modern and stylish aesthetic, while maintaining a welcoming and practical family environment. Connecting the living areas with the installation of a 10 metre long floating concrete bench, and a custom designed American oak sliding panel that's edged in bronze to hide the television, is clear

representation of the thoughtful design aesthetic. The walls are finished in a fresh palette of warm greys, bright whites and rich blacks, while the wall paint stops just short of the ceiling, and is finished with rounded patterns to convey the core inspiration of man-made imperfections. The furniture selection is a reflection of the homeowners' minimalist tendencies, focusing on iconic pieces chosen for their sculptural qualities, that stand beautifully within this home's open spaces.

Key Pieces:

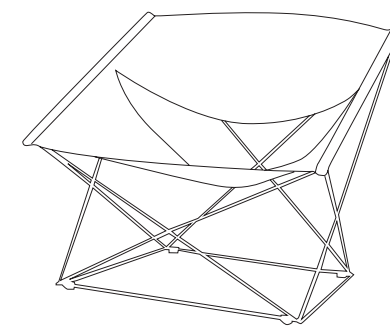

BUTTERFLY CHAIR
by Pierre Paulin
for Artifort
from Matisse
09 302 2284
matisse.co.nz

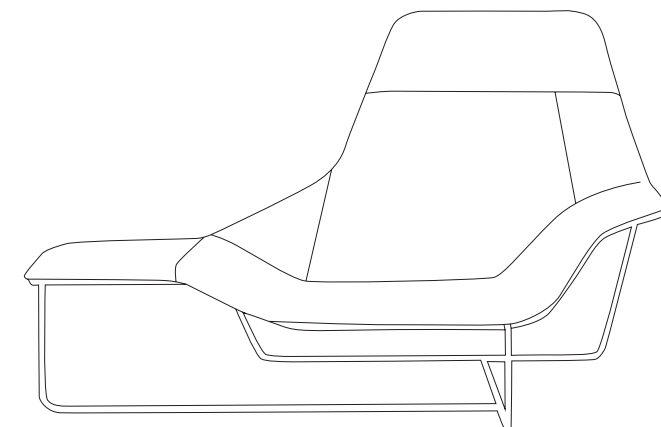

LAMA CHAISE
by Ludovica & Roberto Palomba
for Zanotta
from Studio Italia
09 523 2105
studioitalia.co.nz

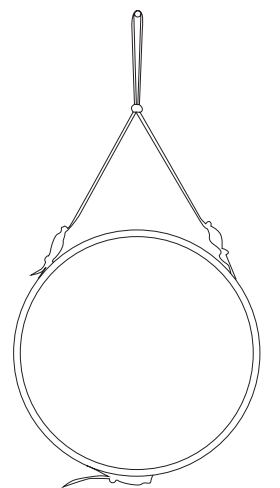

ADNET MIRROR
by Jacques Adnet
for Gubi
from Bromhead
09 366 7322
bromheaddesign.com